

Deutsch Connectors:
 "A" DTM06-12SA (CON70389) + WM-12S (CON70391) + 12x0462-201-20141 (CON70216/5) + DTM12S-BT (CON70914)
 "B" DTM06-12SB (CON70390) + WM-12S (CON70391) + 12x0462-201-20141 (CON70216/5) + DTM12S-BT-BK (CON70913)

Deutsch Accessories:
 Pin Extractor: SRK-RT-01
 Crimping Tool: HDT-48-00

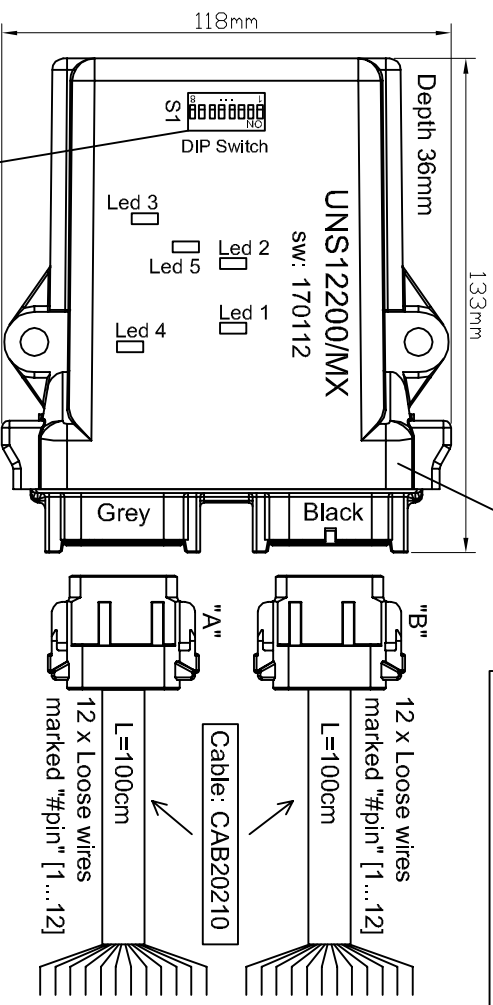

INTERNAL DIAGNOSTIC LED:
 Led 1 (green): SVP - ON => OK
 Led 2 (green): 3V3P - ON => OK
 Led 3 (green): CPU - If Main Running => blinking with T_Oup=1s + T_Off=1s. Otherwise failure => ON (and also during the PowerOn) or OFF.
 Led 4 (green): FAULT - ON => Cumulative Fault reception.
 Led 5 (green): CanBus Status - ON: message transmission or reception.

Dip	Function
1	Always OFF - ON = Rudder calibration input: Zero Increases
2	Always OFF - ON = Rudder calibration input: Zero Decrease
3	Always OFF - ON = Rudder calibration input: Gain Increases
4	Always OFF - ON = Rudder calibration input: Gain Decrease
5	Always OFF - ON = Engine Speed calibration input: Gain Increase
6	Always OFF - ON = Engine Speed calibration input: Gain decrease
7	OFF => Id=0. - ON => Id=1 of Engine Instance for J-1939
8	OFF => Id=0. - ON => Id=1 of Device Instance for NMEA2000

Personalizzazione S1 di default:
 Dip 1 = OFF
 Dip 2 = OFF
 Dip 3 = OFF
 Dip 4 = OFF
 Dip 5 = OFF
 Dip 6 = OFF
 Dip 7 = OFF
 Dip 8 = OFF

External connections

- Connector "A" (DTM06-12SA - Grey)**
- 1: Power supply (12..24Vdc)
 - 2: GND
 - 3: Low Oil Press (***)
 - 4: Over Temperature (switch active when closed to gnd)
 - 5: Battery Voltage 1 (0..32.6V)
 - 6: Not Connected (NC)
 - 7: Not Connected (NC)
 - 8: NMEA 2000 NET-H (CANH)
 - 9: NMEA 2000 NET-L (CANL)
 - 10: NMEA 2000 NET-C (power supply V-)
 - 11: Not Connected (NC)
 - 12: Not Connected (NC)
- (***) switch active when closed to gnd and alarm enabled when engine is running (rpm>300rpm and t>10s)
- Connector "B" (DTM06-12SB - Black)**
- 1: Not Connected (NC)
 - 2: GND
 - 3: Engine Speed (0..10000Hz = 0..16000rpm) (*)
 - 4: Not Connected (NC)
 - 5: Battery Voltage 3 (0..32.6V)
 - 6: Not Connected (NC)
 - 7: Engine Water Temp Input (287..220 = 40..120°C)
 - 8: Engine Oil Press Input (10..1800Ω = 0..10bar)
 - 9: Fuel Level % Input (10..1800Ω = 0..100%)
 - 10: Rudder Angle Input (10..95..1800Ω = +40..0..-40°) (*) (**)
 - 11: Low Sys Volt Sel (Open: V1_T=8V - GND: V1_T=16V)
 - 12: Not Connected (NC)
- (*) with Gain Adj
 (***) with Offset Adj

Pin transmitted on the NMEA 2000 Bus:

Engine Temperature	127489	(0x11201)
Engine Oil Pressure	127489	(0x11201)
Fuel Level Percent	127505	(0x11211)
Rudder Angle	127245	(0x1110d)
Engine Speed	127488	(0x11200)
Battery Voltage 1	127508	(0x11214)
Battery Voltage 3	127508	(0x11214)
Low Oil Pressure	127489	(0x11201)
Over Temperature	127489	(0x11201)
Low System Voltage	127489	(0x11201)

Rev:	Date:	Descrizione modifiche - Description of changes:	
0	12/01/17	Prima emissione	
SAN GIORGIO S.E.I.N. GENOVA - ITALY			
Tel. 010-8301222 - www.sangiorgioseihn.com			
Wiring diagram NMEA2000 Converter - UNS12200/MX			
Number:	Sheet:	Date:	Size:
D170113	1/1	12/01/17	A4
Completed:	Checked:	Approved:	
Garzi P.	Casaretto G.	Manuelli M.	

Se non diversamente specificato, tutte le dimensioni sono da intendersi in mm e le tolleranze delle quote ±0,1mm