

CHALLENGER 45

Foglio 1 di 4

TIPO APPARECCHIO

SUBACQUEI



CARATTERISTICHE GENERALI

MATERIALI

Grado di protezione	IP68	CORNICE	ACCIAIO INOX AISI 316
Applicazione	SCAFO	CORPO	ACCIAIO INOX AISI 316
Cornice	Ø 108 mm	DIFFUSORE	VETRO
Recesso	130 mm		
Foratura	Ø 22 mm		
Peso	1700 gr		
Fissaggio	VITI		
Orientabile	No		
Flessibile	No		
Interruttore	No		

SPECIFICHE ELETTRICHE

TIPO ALIMENTAZIONE

Tensione Costante

Sorgente Luminosa	12 POWER LED
Tipo Apparecchio	Monocolore
Alimentazione	10-30 V
Potenza	45 W
Assorbimento	1,88 A @ 24V
Dimmerabile / Dimmer Consigliato	No

DATI ILLUMINECNICI

Temperatura Colore	BIANCO CALDO (2900-3100 °K)	BIANCO NATURALE (3800-4100 °K)	BIANCO FREDDO (6200-6500 °K)
CRI			
Flusso luminoso			4100 lm
Efficienza			94 lm/W
Ø a 1 m	0,59 m		9888 lux
Ø a 2 m	1,18 m		2472 lux
Ø a 3 m	1,78 m		1098,7 lux
ANGOLO APERTURA	35°		

CERTIFICAZIONI



TIPO APPARECCHIO**SUBACQUEI****SPECIFICHE PER IL COLLEGAMENTO
DEL SINGOLO APPARECCHIO**

Dimensioni in mm (inches)

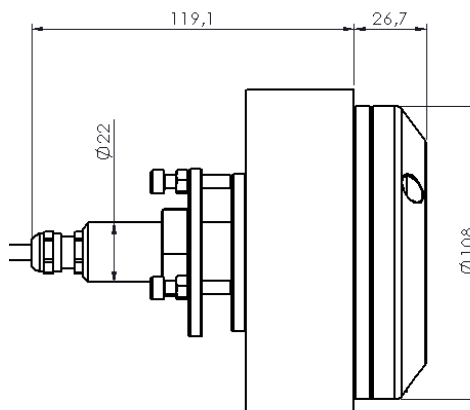
POTENZA: 45 W**ALIMENTAZIONE: 10-30 V****ASSORBIMENTO: 1,88 A @ 24V****INDICAZIONI PER IL COLLEGAMENTO****AVVERTENZE**

Utilizzare l'apparecchio in bassissima tensione (SELV) **Non collegare l'apparecchio direttamente alla corrente di rete (AC).**

INDICAZIONI GENERALI PER COLLEGARE PIU' DI UN APPARECCHIO

Questo prodotto si può collegare in parallelo

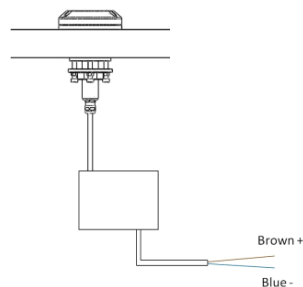
**INDICAZIONI PER IL MONTAGGIO**

Seguire le istruzioni come da manuale

CHALLENGER 45

CATEGORY

UNDERWATER



GENERAL FEATURES

IP Protection grade	IP68
Installation on	HULL
Molding	Ø 108 mm
Recess	130 mm
Mounting hole	Ø 22 mm
Weight	1700 gr
Fixing system	SCREWS
Orientable	No
Flexible	No
Switch	No

MATERIALS

BEZEL	AISI 316 STAINLESS STEEL
BODY	AISI 316 STAINLESS STEEL
DIFFUSER	GLASS

ELECTRICAL SPECIFICATIONS

TYPE OF POWER	Constant Voltage
Light source	12 POWER LED
Light Type	One Color
Power supply	10-30 V
Power consumption	45 W
Absorption	1,88 A @ 24V
Dimmable / Recommended dimmer	No

PHOTOMETRIC DATA

Color Temperature	WARM WHITE (2900-3100 °K)	DAY LIGHT (3800-4100 °K)	COOL WHITE (6200-6500 °K)
CRI			
Luminous flux			4100 lm
Luminous efficacy			94 lm/W
Ø at 1 m 0,59 m			9888 lux
Ø at 2 m 1,18 m			2472 lux
Ø at 3 m 1,78 m			1098,7 lux
ANGLE 35°			

CERTIFICATIONS



CATEGORY**UNDERWATER****SPECIFICATION FOR THE CONNECTION OF INDIVIDUAL UNIT**

Dimensions - mm (inches)

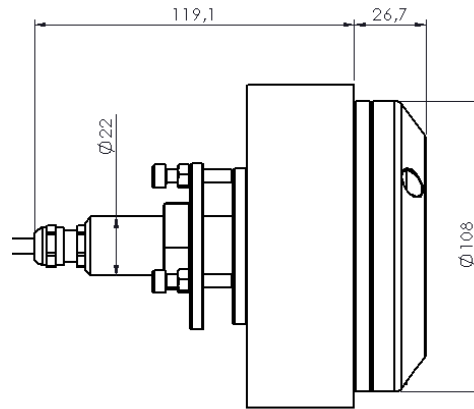
POWER: 45 W**POWER SUPPLY: 10-30 V****OPERATING VOLTAGE****CONNECTION INFORMATION****WARNINGS**

Use the unit in ultra-low voltage (SELV) .
Do not plug the unit directly into the wall socket (AC).

GENERAL INFORMATION TO CONNECT MORE THAN ONE DEVICE

This product can be connected in parallel

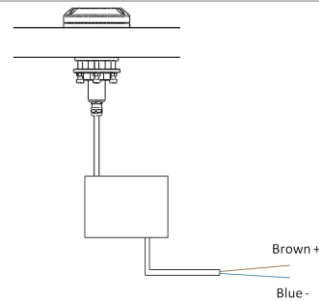
**INSTRUCTIONS FOR ASSEMBLY**

See installation instruction